

# envie<sup>3</sup>

## VERSATILITY MEETS HIGH PERFORMANCE

Envie<sup>3</sup> high efficiency air-filled motors come without application limitations. This next generation of dry pit submersible pumps can run in wet and dry pit applications. These pumps took Barnes' and Deming's proven solids handling and chopper wet ends and outfitted it with a premium efficient/IE3 motor that can run in both vertical and horizontal configurations.

### FEATURES AND BENEFITS

- Patent pending, **closed loop glycol cooling system** that keeps motors stress-free, even in the most demanding applications
- **Premium efficient IE3 motor** that delivers significant energy savings versus traditional motor offerings
- **Available for both solids handling and chopper pumps**; one of the market's most flexible solutions
- **Made in the USA** with best in class manufacturing lead times
- Available in **both vertical and horizontal configurations**, and offered with a variety of user-friendly mounting hardware options
- **Easy to service** with plug & play cord and commercially available mechanical seals and bearing components
- **Rugged and modern design** that looks great out of the box, and for years to come
- **Suitable for shallow wells, high water tables, and rocky terrain**
- **High temperature option** (140°F/60°C) available for the harshest applications
- Extensive **sensing package** for reliable protection\*

\*E36 Frame Only

## OUR VERSATILE PORTFOLIO OPTIONS HAVE YOU COVERED!



High Temperature



Sensing Package\*



Accessories

- 1 Large Stainless Steel Handle
- 2 Plug & Play Quick Connect Cord
- 3 IE3 Premium Efficient Motor /VFD Ready
- 4 Tapered Keyed Shaft
- 5 Closed Loop Cooling System
- 6 Stainless Steel Outer Shell / Stainless Steel Hardware  
(Cast Iron on E36 Frame)
- 7 Resicoat R4 Powder Coating
- 8 High Capacity Sealed Bearings
- 9 Explosion Proof Option
- 10 Sensing Package that protects against winding failures,  
leaks, high temperature damage and excessive vibration \*

\*E36 Frame Only

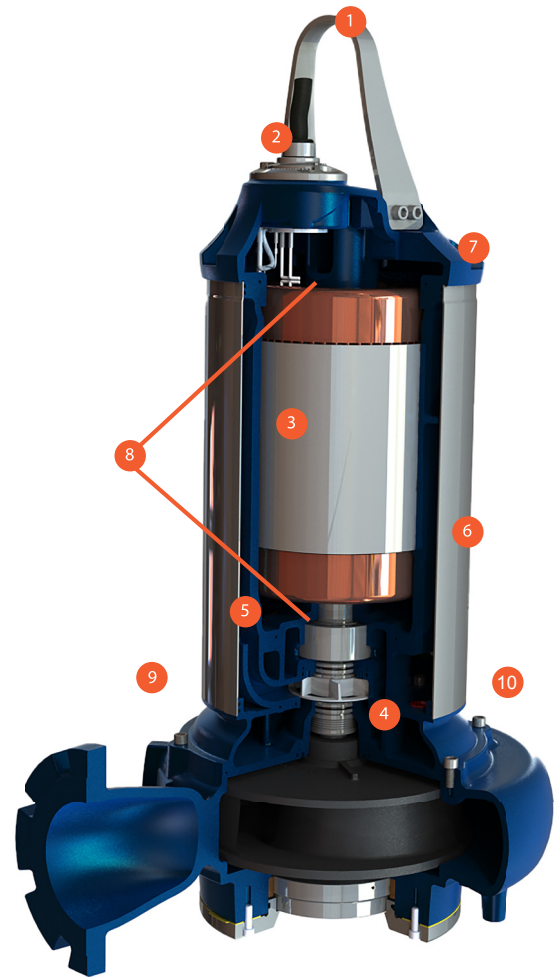

## APPLICATIONS



MUNICIPAL



COMMERCIAL



INDUSTRIAL

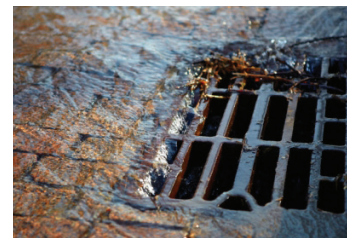

STORM RUN-OFF

...AND MANY MORE

**BARNES®**

**DEMING®**

**CRANE**  
PUMPS & SYSTEMS